



## Requirements for Non-Commercial Emergency/Standby Generation

This document outlines the necessary steps for non-commercial members to connect standby generators to Medina Electric Cooperative's (Medina EC's) electric distribution system. Standby generators are useful when temporary power is needed, and they can provide an alternate source of electrical power for all or part of a member's load in the event of an outage. However, members should understand that standby generators shall not export power (also known as parallel or distributed generation) to Medina EC's distribution system. As such, requirements for member-owned generators that are intended to export power to Medina EC's system are not addressed by this document. For information on member-owned distributed generation, please refer to Medina EC's [Retail Tariff, found at MedinaEC.org/CorpDoc](#), for Medina EC's Interconnection Policy.

### For Member To Do

- Before installing a generator, contact Medina EC at [Info@MedinaEC.org](mailto:Info@MedinaEC.org) or by calling 1-866-632-3532.
- Use one of the diagrams in this document, add any notes/modifications as needed, and complete the associated checklist for that diagram. Submit both the diagram and checklist to Medina EC at [Info@MedinaEC.org](mailto:Info@MedinaEC.org) or by dropping it off at one of our area offices or mailing it to Medina EC, PO Box 69, Hondo TX, 78861.
- Members with a 200 Amp or smaller service that want the convenience of operating a standby generator without installing transfer switches, subpanels, and rewiring work may want to have a [GenerLink](#) device. GenerLink is installed behind your meter by Medina EC crews and is billed monthly on your electric bill.
- If you are increasing your main breaker size you will need to submit an [Upgrade Form](#) located at [MedinaEC.org/NewService](http://MedinaEC.org/NewService).

### Safety and Requirements

- A single generator cannot be connected to feed multiple meters. Each meter must have its own generator to meet safety requirements.
- Be aware that it is a potential safety and fire hazard to connect a generator to a home's electrical circuits without a generator transfer switch. Improperly installed generators can create hazardous conditions for members and for Medina EC employees working to restore power or make repairs.
- Members may only use a Medina EC-approved open-transition transfer switch to connect a generator. An open-transition transfer switch breaks the circuit connection to Medina EC's service wires before making the circuit with the member's generation and, conversely, breaks the circuit connection to the member's generation before connection to Medina EC service.
- Member generator installations must meet all local, municipal, National Electrical Safety Code (NESC) and National Electrical Code (NEC) regulations. Medina EC reserves the right to disconnect or refuse service to any generator installation which violates said regulations. Medina EC shall also have the right to disconnect or refuse service for



Your Touchstone Energy® Cooperative 

## Requirements for Non-Commercial Emergency/Standby Generation

installations that are hazardous to the public, or that may negatively impact service to other members or Medina EC facilities/equipment.

- Member generator installations must also meet the requirements of Medina EC's Single Phase Wiring Specifications or Three Phase Wiring Specifications found at [MedinaEC.org/New Service](http://MedinaEC.org/New Service) under Wiring Specifications or provided upon request.
- Know your generator. Read all the information and materials provided with your generator and follow instructions regarding installation, safety, maintenance, and testing.

### Liability

- Any review or acceptance of an application by Medina EC shall not impose any liability on Medina EC and does not guarantee the adequacy of member's equipment to perform its intended function. Medina EC disclaims any expertise or special knowledge relating to the design or performance of generating installations and does not warrant the efficiency, cost-effectiveness, safety, durability, or reliability of generating installations. Medina EC assumes no liability for the protection of any property or person associated with a generator's operation.
- Generator owners are responsible for providing and maintaining all equipment deemed necessary for the protection of member-owned property and operations.
- Generator owners are responsible for the proper installation and operation of the facility and will indemnify and hold Medina EC harmless from liability for damage to property or person resulting from or arising out of or in any way connected with the installation, inspection, operation, maintenance, testing, and/or use of the generator

### What to Expect

- Once member submits the schematic and checklist, staff will review it within 2 weeks.
- Once approved, member can proceed with installation. A temporary disconnect can be requested by contacting Medina EC at 1-866-632-3532. Once installation is complete, member will need to notify Medina EC so it can be inspected by staff.
- If the installation doesn't meet the schematic that was approved, power will be disconnected.

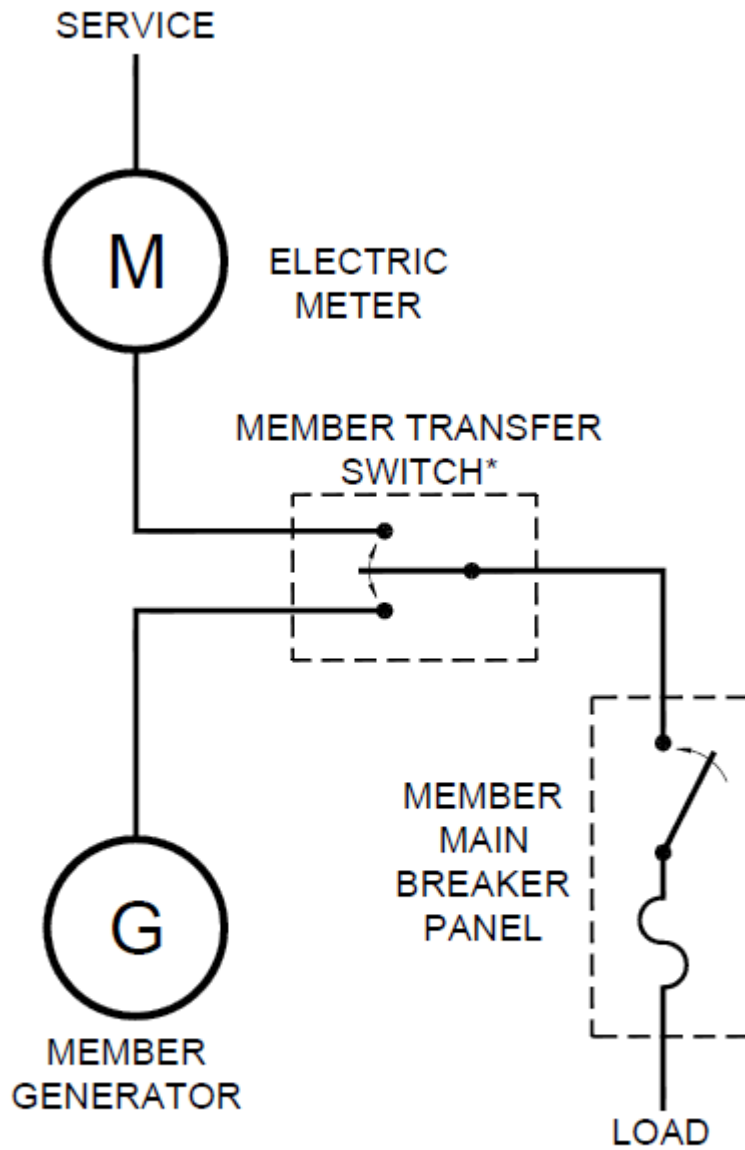

\*DOUBLE POLE, DOUBLE THROW, NON-FUSIBLE "BREAK BEFORE MAKE" SWITCH

Figure 1: Typical standby generator with transfer switch one-line diagram

### Requirements for Non-Commercial Emergency/Standby Generation

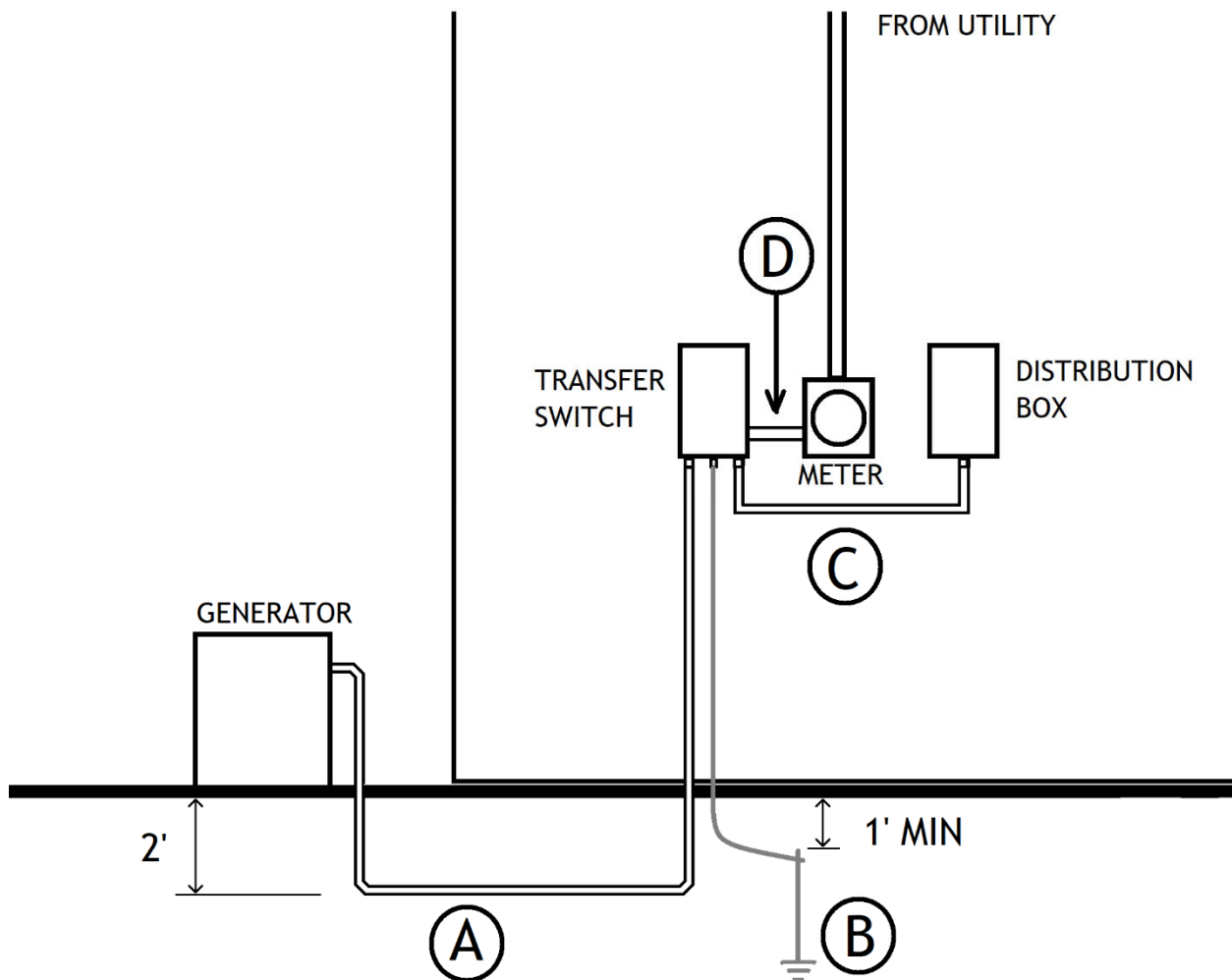

Figure 2: Typical Standby generator with overhead utility and house mounted meter

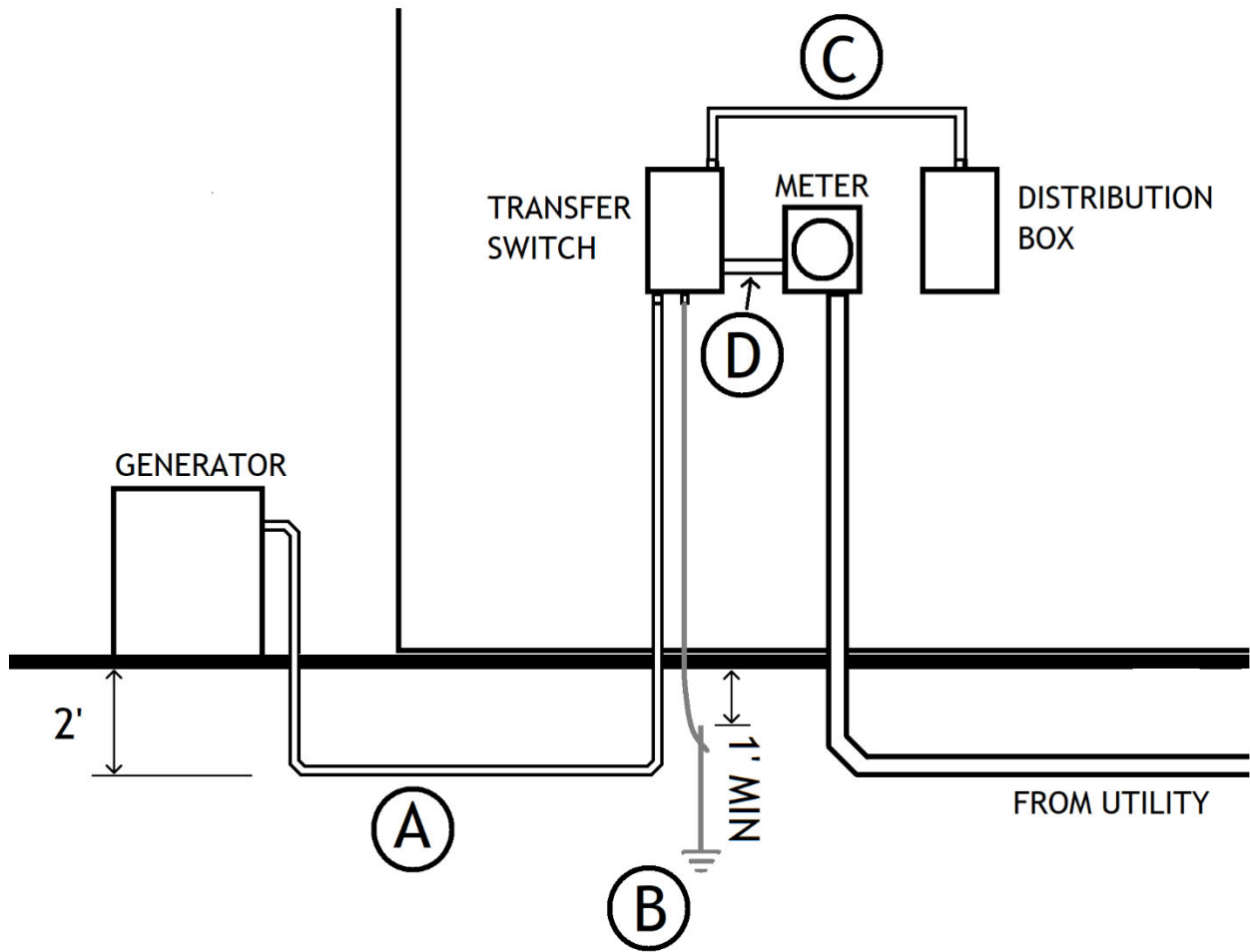

Figure 3: Typical Standby generator with underground utility and house mounted meter



## Requirements for Non-Commercial Emergency/Standby Generation

### STANDBY GENERATOR: HOUSE MOUNTED METER CHECKLIST (1 of 2)

Member / Account Name: \_\_\_\_\_

Meter Number: \_\_\_\_\_

Main Breaker Size (Amps): \_\_\_\_\_

Are you increasing your main breaker size? Y N

If so, have you submitted the MEC upgrade form? Y N

Meter Loop Rating (Amps): \_\_\_\_\_

Transfer Switch Rating (Amps): \_\_\_\_\_

Generator Size (kW): \_\_\_\_\_

*\*Refer to the Medina EC Single, or Three, Phase Wiring Specification Ampacity and Grounding Electrode Conductor tables for the phase conductor, neutral, grounding and conduit requirements\**

#### A. Generator to Transfer Switch

1. Phase Conductor Wire Type & Gauge: \_\_\_\_\_

2. Neutral Wire Type & Gauge (No RN): \_\_\_\_\_

3. Conduit Size: \_\_\_\_\_

4. Bonding Conductor Gauge: \_\_\_\_\_

#### B. Grounding

1. Grounding Electrode Diameter (5/8" MIN): \_\_\_\_\_

2. Grounding Electrode Length (8' MIN): \_\_\_\_\_

3. Grounding Electrode Burial Depth (12" MIN): \_\_\_\_\_

4. Grounding Conductor Gauge: \_\_\_\_\_



## Requirements for Non-Commercial Emergency/Standby Generation

### STANDBY GENERATOR: HOUSE MOUNTED METER CHECKLIST (2 of 2)

#### C. Transfer Switch to Distribution Box

1. Overcurrent device installed for each ungrounded conductor (Required):    Y        N
2. Phase Conductor Wire Type & Gauge: \_\_\_\_\_
3. Neutral Wire Type & Gauge (No RN): \_\_\_\_\_
4. Conduit Size: \_\_\_\_\_
5. Conduit Type (EMT or Rigid Required): \_\_\_\_\_
6. Bonding Conductor Gauge: \_\_\_\_\_

#### D. Meter to Transfer Switch

1. Phase Conductor Wire Type & Gauge: \_\_\_\_\_
2. Neutral Wire Type & Gauge (No RN): \_\_\_\_\_
3. Conduit Size: \_\_\_\_\_
4. Conduit Type (EMT or Rigid Required): \_\_\_\_\_

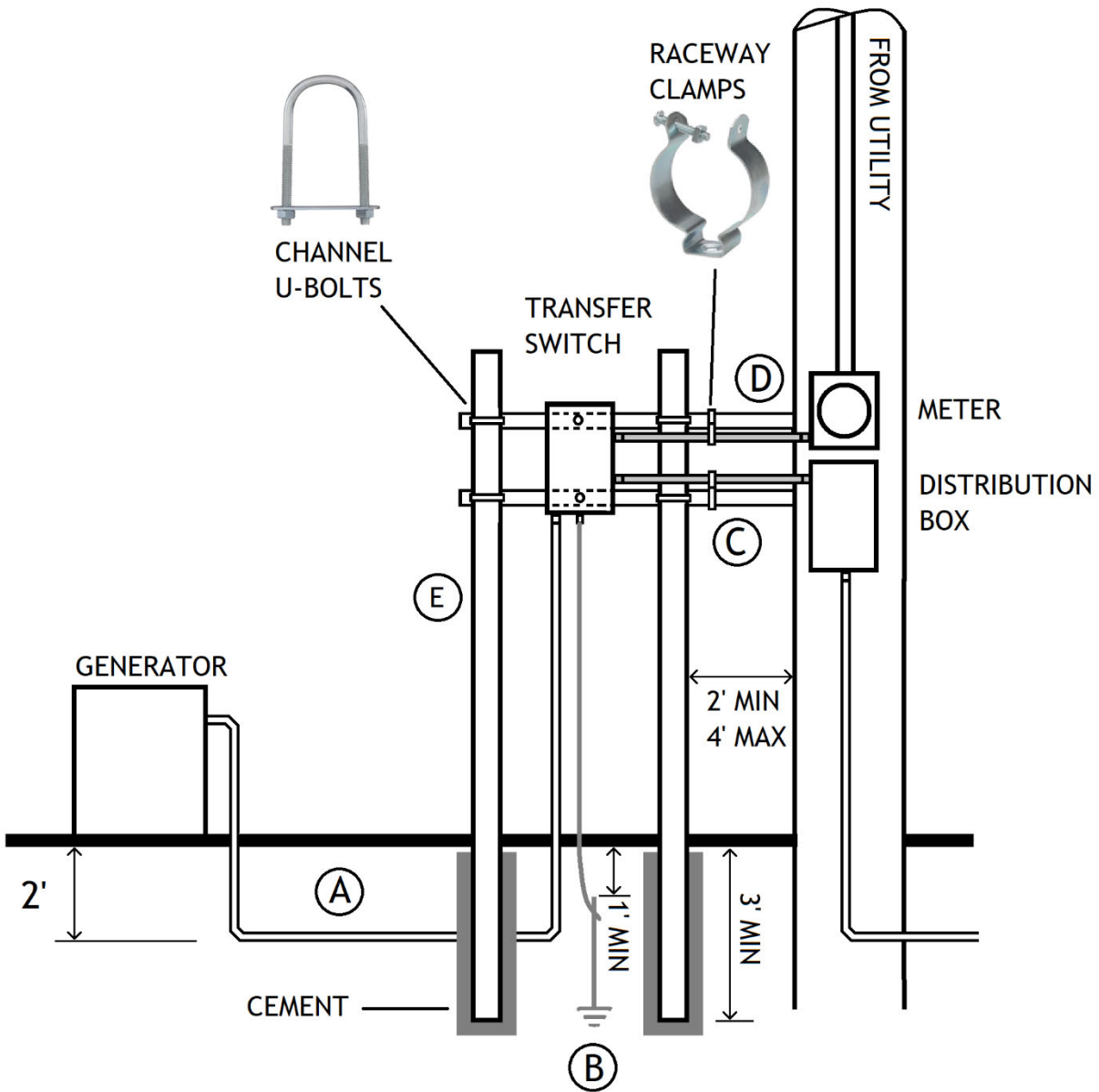

Figure 4: Typical Standby Generator with pole mounted meter





## Requirements for Non-Commercial Emergency/Standby Generation

### STANDBY GENERATOR: POLE MOUNTED METER CHECKLIST (1 of 2)

Member / Account Name: \_\_\_\_\_

Meter Number: \_\_\_\_\_

Main Breaker Size (Amps): \_\_\_\_\_

Are you increasing your main breaker size? Y N

If so, have you submitted the MEC upgrade form? Y N

Meter Loop Rating (Amps): \_\_\_\_\_

Transfer Switch Rating (Amps): \_\_\_\_\_

Generator Size (kW): \_\_\_\_\_

*\*Refer to the Medina EC Single, or Three, Phase Wiring Specification Ampacity and Grounding Electrode Conductor tables for the phase conductor, neutral, grounding and conduit requirements\**

#### A. Generator to Transfer Switch

1. Phase Conductor Wire Type & Gauge: \_\_\_\_\_

2. Neutral Wire Type & Gauge (No RN): \_\_\_\_\_

3. Conduit Size: \_\_\_\_\_

4. Bonding Conductor Gauge: \_\_\_\_\_

#### B. Grounding

1. Grounding Electrode Diameter (5/8" MIN): \_\_\_\_\_

2. Grounding Electrode Length (8' MIN): \_\_\_\_\_

3. Grounding Electrode Burial Depth (12" MIN): \_\_\_\_\_

4. Grounding Conductor Gauge: \_\_\_\_\_



## Requirements for Non-Commercial Emergency/Standby Generation

### STANDBY GENERATOR: POLE MOUNTED METER CHECKLIST (2 of 2)

#### C. Transfer Switch to Distribution Box

1. Overcurrent device installed for each ungrounded conductor (Required):    Y    N
2. Phase Conductor Wire Type & Gauge: \_\_\_\_\_
3. Neutral Wire Type & Gauge (No RN): \_\_\_\_\_
4. Conduit Size: \_\_\_\_\_
5. Conduit Type (EMT or Rigid Required): \_\_\_\_\_
6. Bonding Conductor Gauge: \_\_\_\_\_

#### D. Meter to Transfer Switch

1. Phase Conductor Wire Type & Gauge: \_\_\_\_\_
2. Neutral Wire Type & Gauge (No RN) \_\_\_\_\_
3. Conduit Size: \_\_\_\_\_
4. Conduit Type (EMT or Rigid Required): \_\_\_\_\_

#### E. Transfer Switch Rack

1. Vertical poles diameter greater than or equal to 2" (Required):    Y    N
2. Vertical poles buried 3' in cement (Required):    Y    N
3. 5/16" U bolts used for channel to pole connection (Required):    Y    N
4. Horizontal channel size: \_\_\_\_\_